

V-BLOCK ATTACHMENT- PEL-VBLK

APPROX WEIGHT: 26.40 lbs.
 DOES NOT INCLUDE WEIGHT OF POWER OR PACKAGING!!!

*** ANY ADDITIONS, DELETIONS, OR OMISSIONS MUST BE CORRECTED ON THIS DRAWING AS THIS DRAWING WILL BE CONSIDERED ALL INCLUSIVE ***

ALL GRAPHICS PROVIDED ARE FOR REFERENCE ONLY. IF CERTAIN DIMENSIONS ARE CRITICAL PLEASE VERIFY THOSE DIMENSIONS WITH YOUR SALESPERSON

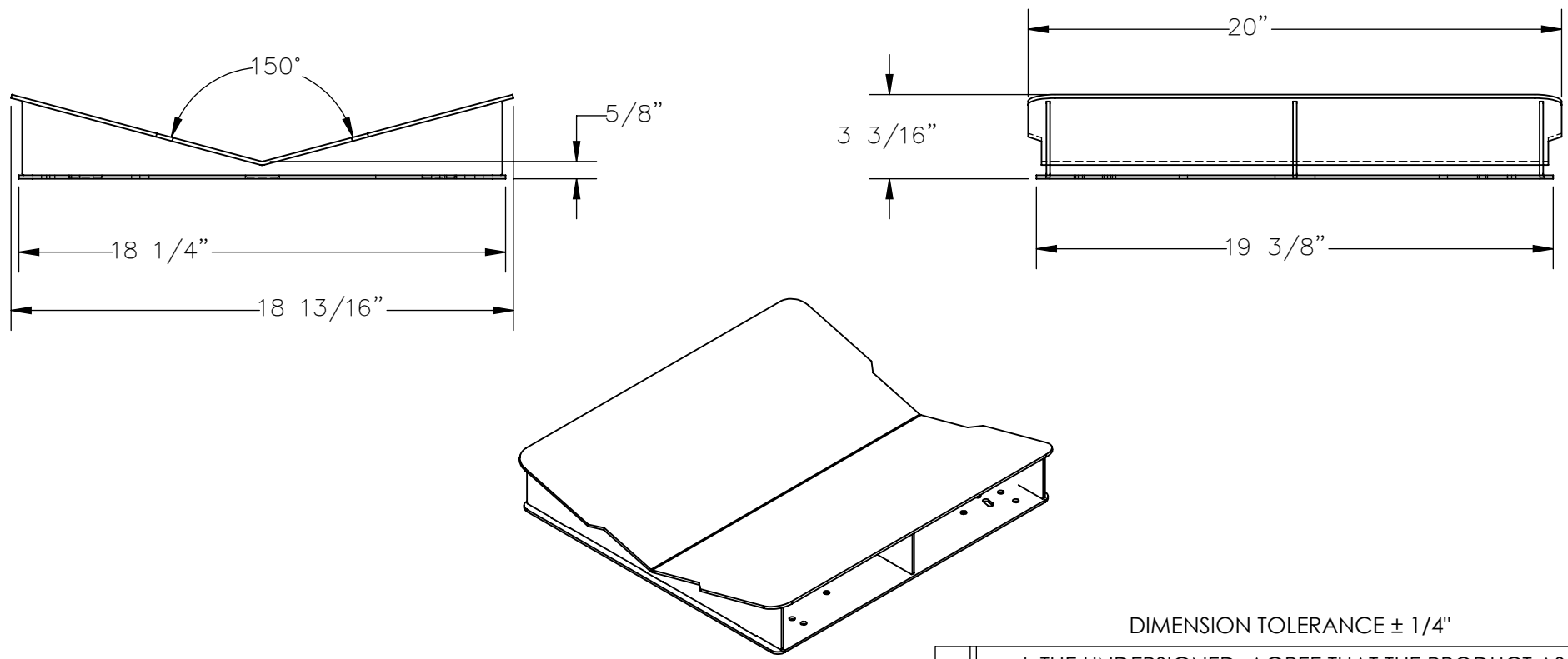

STANDARD FEATURES

MODEL# PEL-VBLK
 OVERALL LENGTH IS 19 3/8"
 OVERALL WIDTH IS 18 13/16"
 OVERALL HEIGHT IS 3 3/16"

DECK CAN BE ALIGNED SO
 THE V-GROOVE IS PARALLEL OR
 PERPENDICULAR TO CARRIAGE

TOTAL MAXIMUM CAPACITY FOR:
 PEL-88 & PEL-88-A: 175 LBS
 PEL-100 & PEL-100-A: 125 LBS
 PEL-400-57/72: 400 LBS
 TOUGH BAKED IN POWDER COATED YELLOW FINISH

SPECIAL FEATURES

NONE

DIMENSION TOLERANCE ± 1/4"

APPROVAL	I, THE UNDERSIGNED, AGREE THAT THE PRODUCT AS REPRESENTED SATISFIES DESIGN AND DIMENSION REQUIREMENTS. I ALSO ACKNOWLEDGE MY DUTY TO CONFIRM PRODUCT AND INSTALLATION COMPLIANCE WITH ALL APPLICABLE FEDERAL, STATE AND LOCAL REGULATIONS AND STANDARDS.	
	UNITS REQUIRING APPROVAL DRAWINGS OR MODIFIED ARE NON-RETURNABLE	
	[] As drawn [] As marked	
	Signed: _____	Date: _____
Printed Name: _____		
LEAD TIME WILL START UPON RECEIPT OF SIGNED APPROVAL DRAWING		

DISTRIBUTOR'S NAME:		P.O.#
VESTIL MANUFACTURING		X
DRAWN BY: SJA		W.O.#
DATE: 03/24/2016		X
REFERENCE: X	SCALE: 1:6	SALES: X
QUOTED LEAD TIME: X	QUOTE #	FILE NAME:
	X	21-007-119